

LG Programmable Logic Controller

GLOFA ***MASTER-K***

G3F-DA3V

G3F-DA3I

G4F-DA3V

G4F-DA3I

G4F-DA2V

G4F-DA2I

G6F-DA2V

G6F-DA2I



LG Industrial Systems



SAFETY PRECAUTIONS

Be sure to read carefully the safety precautions given in data sheet and user's manual before operating the module and follow them.

The precautions explained here only apply to the G3F-DA3V/G3F-DA3I, G4F-DA3V/G4F-DA2V, G4F-DA3I/G4F-DA2I, G6F-DA2V/G6F-DA2I (hereafter, called D/A conversion module)

For safety precautions on the PLC system, see the GLOFA GM3, GM4, GM6 User's Manuals and the MASTER-K200S/300S/1000S User's Manuals.

A precaution is given with a hazard alert triangular symbol to call your attention, and precautions are represented as follows according to the degree of hazard.

 WARNING	⇒	If not provided with proper prevention, it can cause death or fatal injury or considerable loss of property.
 CAUTION	⇒	If not properly observed, it can cause a hazard situation to result in severe or slight injury or a loss of property.

However, a precaution followed with  **CAUTION** can also result in serious conditions.

Both of two symbols indicate that an important content is mentioned, therefore, be sure to observe it.

Keep this manual handy for your quick reference in necessary.

Design Precautions

 CAUTION		
Design a safety circuit in the outside of the PLC for system safety in case of disorder of the external power or PLC module body. Otherwise, it can cause injury due to wrong output or malfunction.		
1) The following shows analog output states according to various settings of functions that control analog output. When setting an output state, be cautious for safety.		
State	Channel Specification	
	Used	Unused
PLC CPU in RUN state.	A D/A conversion value is output.	Voltage: 0 V Current: 4mA
PLC CPU in STOP state	Voltage: 0V, Current: 4mA	
PLC CPU in Error state		
2) Sometimes, fault of output device or internal circuit can make output abnormal. Design a supervising circuit in the outside for output signals which can cause serious accidents.		

 CAUTION
Do not run I/O signal lines near to high voltage line or power line. Separate them as 100 mm or more as possible. Otherwise, noise can cause module malfunction.

Installation Precautions



CAUTION

Operate the PLC in the environment conditions given in the general specifications.

If operated in other environment not specified in the general specifications, it can cause an electric shock, a fire, malfunction or damage or degradation of the module.

Make sure the module fixing projections is inserted into the module fixing hole and fixed.

Improper installation of the module can cause malfunction, disorder or falling.

Wiring Precautions



CAUTION

When grounding a FG terminal, be sure to provide class 3 grounding which is dedicated to the PLC.

Before the PLC wiring, be sure to check the rated voltage and terminal arrangement for the module and observe them correctly.

If a different power, not of the rated voltage, is applied or wrong wiring is provided, it can cause a fire or disorder of the module.

Drive the terminal screws firmly to the defined torque.

If loosely driven, it can cause short circuit, a fire or malfunction.

Be careful that any foreign matter like wire scraps should not enter into the module.

It can cause a fire, disorder or malfunction.

Test Run and Maintenance Precautions



WARNING

Do not contact the terminals while the power is applied. It can cause malfunction.

When cleaning or driving a terminal screw, perform them after the power has been turned off.

Do not perform works while the power is applied, which can cause disorder or malfunction.



CAUTION

Do not separate the module from the printed circuit board(PCB), or do not remodel the module.

They can cause disorder, malfunction, and damage of the module or a fire.

When mounting or dismounting the module, perform them after the power has been turned off.

Do not perform works while the power is applied, which can cause disorder or malfunction.

Waste Disposal Precautions



CAUTION

When disposing the module, do it as an industrial waste.

CONTENTS

Chapter 1. INTRODUCTION

1.1 Features	1-1
1.2 Glossary	1-1
1.2.1 A-Analog Value	1-1
1.2.2 D-Digital Value	1-2
1.2.3 Digital / Analog Conversion Characteristics	1-2

Chapter 2. SPECIFICATIONS

2.1 General Specifications	2-1
2.2 Performance Specifications	2-2
2.3 Names of Parts and Functions	2-4
2.4 Input/Output Conversion Characteristics	2-7

Chapter 3. INSTALLATION AND WIRING

3.1 Installation	3-1
3.1.1 Installation Environment.....	3-1
3.1.2 Installation Precautions	3-1
3.2 Wiring	3-2
3.2.1 Wiring Precautions	3-2
3.2.2 Wiring Examples	3-2
1) G3F-DA3V/G4F-DA3V/G4F-DA2V/G6F-DA2V	3-2
2) G3F-DA3I/G4F-DA3I/G4F-DA2I/G6F-DA2I	3-3

Chapter 4. FUNCTION BLOCK

4.1 Insertion of the Function Block for the D/A Conversion Module on the GMWIN	4-1
4.2 Function Block for Local	4-2
4.2.1 Module Write_Array Type (G3F-DA3V,G3F-DA3I,G4F-DA3V,G4F-DA3I : DA3AWR, G4F-DA2V,G4F-DA2I,G6F-DA2V,G6F-DA2I : DA2AWR)	4-2

4.2.2	Module Write_Single Type (G3F-DA3V,G3F-DA3I,G4F-DA3V,G4F-DA3I : DA3WR, G4F-DA2V,G4F-DA2I,G6F-DA2V,G6F-DA2I : DA2WR)	4-3
4.3	Remote Function Block	4-4
4.3.1	Module Write (G3F-DA3V,G3F-DA3I : DAR33WR, G4F-DA3V,G4F-DA3I : DAR3WR, G4F-DA2V,G4F-DA2I : DAR2WR, G6F-DA2V,G6F-DA2I : DAR62WR)	4-4
4.4	Errors on Function Block	4-5

Chapter 5. GM PROGRAMMING

5.1	Programming for Controlling Inverter Speed with 5 Step Analog Output Voltage	5-1
5.2	Programming for Displaying D/A Conversions which is Set by Digital Switch	5-4
5.3	Programming for Mounting D/A Conversion Module on Remote I/O Station	5-7

Chapter 6. BUFFER MEMORY CONFIGURATION AND FUNCTION

6.1	Buffer Memory Configuration.....	6-1
6.2	Buffer Memory Functions	6-1

Chapter 7. SPECIAL MODULE COMMAND (Buffer Memory READ / WRITE)

7.1	Local Command	7-1
7.2	Remote Command	7-2

Chapter 8. MK PROGRAMMING

8.1	Basic Programming	8-1
8.2	Application Programming	8-2
8.2.1	Programming for Controlling Inverter Speed with 5-step Analog Output Voltage	8-2
8.2.2	Programming for Display of D/A Conversion Value and Error Code on BCD Display	8-4
8.2.3	Programming for Loading the D/A Conversion Module on Remote I/O Station	8-6

Chapter 9. DIMENSIONS

9.1	G3F-DA3V/G3F-DA3I	9-1
9.2	G4F-DA3V/G4F-DA3I/G4F-DA2V/G4F-DA2I	9-2
9.3	G6F-DA2V/G6F-DA2I	9-3

Chapter 1. INTRODUCTION

The G3F-DA3V/G3F-DA3I, G4F-DA3V/G4F-DA3I, the G4F-DA2V/G4F-DA2I and G6F-DA2V/G6F-DA2I are digital/analog conversion modules for use with the GLOFA PLC GM1/2/3/4/6 series CPU module and the MASTER-K200S/300S/1000S series CPU module. (Hereafter the G3F-DA3V/G3F-DA3I, G4F-DA3V/G4F-DA3I, G4F-DA2V/G4F-DA2I and G6F-DA2V/G6F-DA2I are called the D/A conversion module)

The D/A conversion module is to convert a 16-bit, signed BIN digital value into an analog output signal (voltage or current).

1.1 Features

1) Allows digital to analog conversion for 8 channels/4 channels per a module.

G3F-DA3V: 1 module can be performed for D/A conversion (voltage output) of 8 channels.

G4F-DA3V: 1 module can be performed for D/A conversion (voltage output) of 8 channels.

G4F-DA2V: 1 module can be performed for D/A conversion (voltage output) of 4 channels.

G6F-DA2V: 1 module can be performed for D/A conversion (voltage output) of 4 channels.

G3F-DA3I: 1 module can be performed for D/A conversion (current output) of 8 channels.

G4F-DA3I: 1 module can be performed for D/A conversion (current output) of 8 channels.

G4F-DA2I: 1 module can be performed for D/A conversion (current output) of 4 channels.

G6F-DA2I: 1 module can be performed for D/A conversion (current output) of 4 channels.

2) The number of the G3F-DA3V/G4F-DA3V/G4F-DA2V/G6F-DA2V and G3F-DA3I/G4F-DA3I/G4F-DA2I/G6F-DA2I used on a base unit is limitless.

But the number of module is limited by capacity of the power supply module.

1.2 Glossary

1.2.1 A - Analog Value

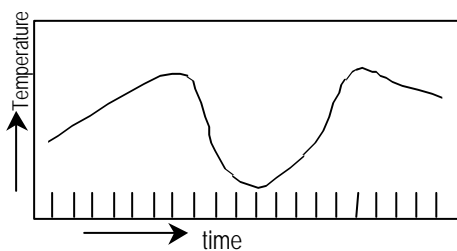

[Fig 1.1] Analog Value

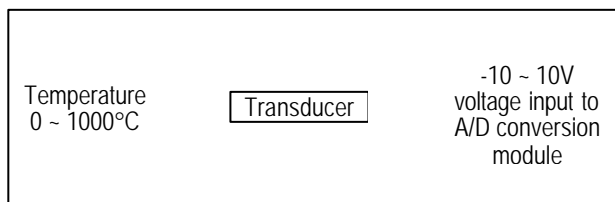

[Fig 1.2] Example of Transducer

Analog value is a sequentially changing value such as voltage, current, temperature, speed, pressure, flux, etc.

Temperature, for example, is sequentially changing according to the time. Because this temperature is not inputted on the PLC directly, the same analog value of DC voltage (0 to 10V) or current (4 to 20mA) in accordance with the temperature should be input on the PLC through transducer.

1.2.2 D - Digital Value

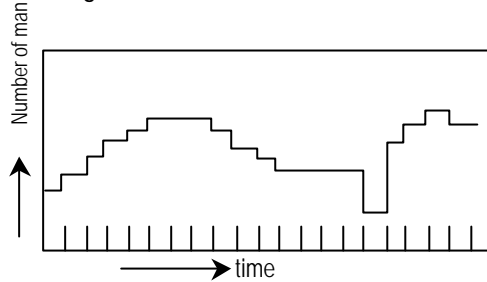

[Fig. 1.3] Digital quality

Digital value is non-sequentially changing value written as the number like 0, 1, 2, 3. The signal of on or off is written as digital value of 0 or 1. There are BCD value and binary value in the range of digital value.

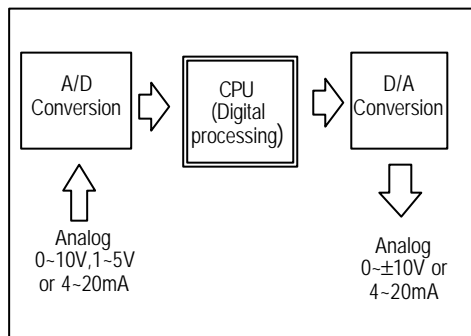

[Fig. 1.4] conversion processing in the PLC

Analog value isn't written directly on the CPU. For analog input to the CPU operation, analog converted to digital value has to be input on the CPU. and for analog output, the digital of CPU should be converted to analog.

1.2.3 Digital/ Analog Conversion Characteristics

1) Voltage output - G3F-DA3V

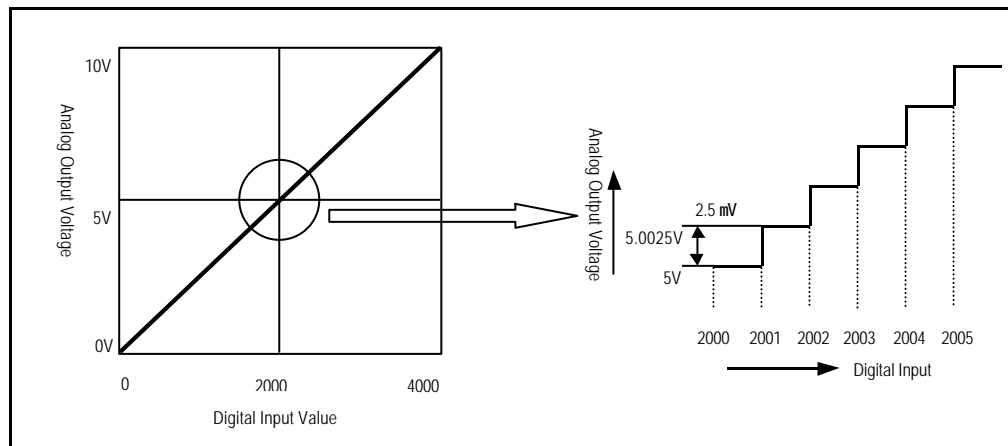

[Fig 1.5] D/A conversion characteristics(Voltage output)

Digital/analog conversion module allows digital value of the CPU to be converted into an analog value and to be output externally. Digital input value of 0 leads to analog output value of 0V and 4000 leads to 10V. Digital input value of 1 is equal to 2.5mV.

2) Voltage output - G4F-DA3V/G4F-DA2V/G6F-DA2V

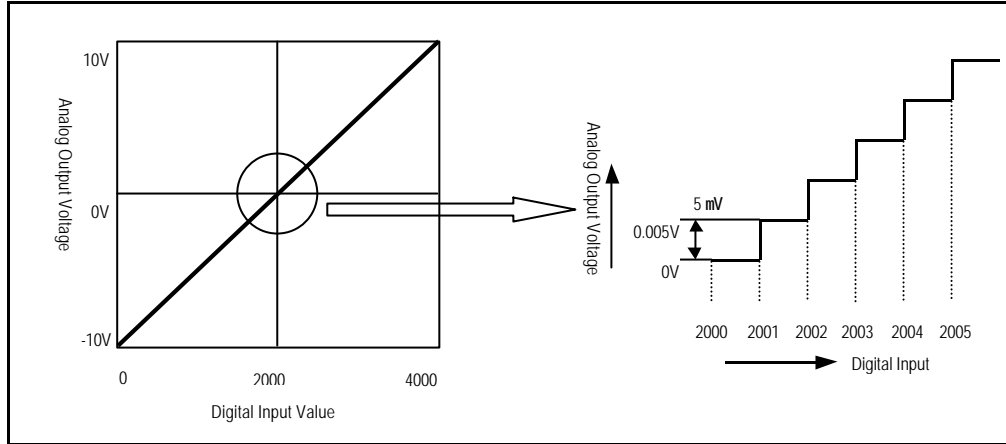

[Fig 1.6] D/A conversion characteristics(Voltage output)

Digital/analog conversion module allows digital value of the CPU to be converted into an analog value and to be output externally. Digital input value of 0 leads to analog output value of -10V and 4000 leads to 10V. Digital input value of 1 is equal to 5mV.

3) Current output – G3F-DA3I/G4F-DA3I/G4F-DA2I/G6F-DA2I

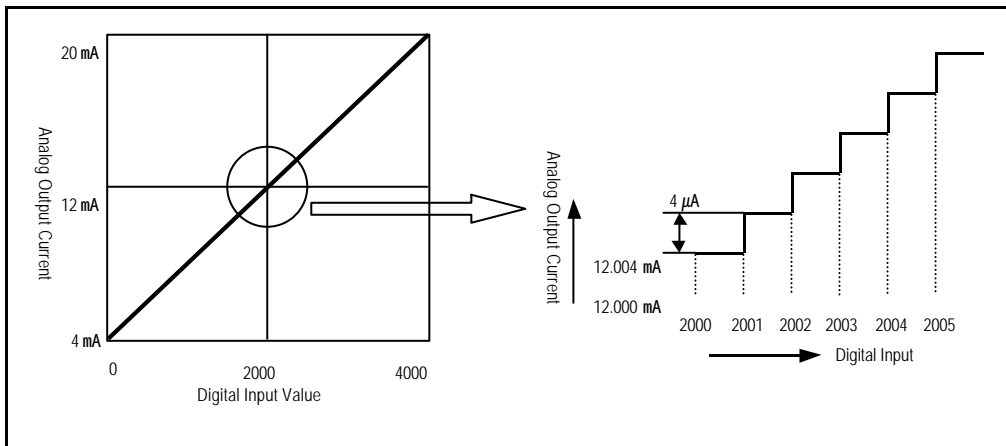

[Fig 1.7] D/A conversion characteristics(Current output)

On current output, digital value of 0 is to be converted into 4mA and 4000 into 20mA. Digital input of 1 is equal to 4 μA.

Chapter 2. SPECIFICATIONS

2.1 General Specifications

Table 2.1 shows the common specifications of the GLOFA GM series and the MASTER-K series.

No	Items	Specifications	Reference Specification				
1	Operating ambient temperature	0 ~ 55					
2	Storage ambient temperature	-25 ~ 70					
3	Operating ambient humidity	5 ~ 95%RH, non-condensing					
4	Storage ambient humidity	5 ~ 95%RH, non-condensing					
5	Vibration	Occasional vibration				IEC 61131-2	
		Frequency	Acceleration	Amplitude	Sweep count		
		10 f 57 Hz	-	0.075mm	10 times in each direction for X, Y, Z		
		57 f 150 Hz	9.8 m/s ² {1G}	-			
		Continuous vibration					
		Frequency	Acceleration	Amplitude			
		10 f 57 Hz	-	0.035mm			
57 f 150 Hz	4.9 m/s ² {0.5G}	-					
6	Shocks	<ul style="list-style-type: none"> Maximum shock acceleration: 147 m/s² {15G} Duration time :11ms Pulse wave: half sine wave pulse (3 times in each of X, Y and Z directions) 	IEC 61131-2				
7	Noise immunity	Square wave impulse noise	± 1,500 V			LGIS Standard	
		Electrostatic discharge	Voltage :4kV(contact discharge)			IEC 61131-2 IEC 1000-4-2	
		Radiated electromagnetic field	27 to 500 MHz, 10V/m			IEC 61131-2 IEC 1000-4-3	
		Fast transient & burst noise	Severity Level	All power modules	Digital I/Os(Ue ≥ 24 V)	Digital I/Os (Ue < 24 V) Analog/Os communication I/Os	IEC 61131-2 IEC 1000-4-4
		Voltage	2kV	1kV	0.25kV		
8	Operating atmosphere	Free from corrosive gases and excessive dust					
9	Altitude for use	Up to 2,000m					
10	Pollution degree	2 or lower					
11	Cooling method	Self-cooling					

[Table 2.1] General Specifications

Remark
<p>1) IEC(International Electrotechnical Commission) :The international civilian organization which produces standards for electrical and electronics industry.</p> <p>2) Pollution degree :It indicates a standard of operating ambient pollution level. The pollution degree 2 means the condition in which only non conductive pollution occurs. Occasionally, however, a temporary conductivity caused by condensation shall be expected.</p>

2.2 Performance Specifications

Table 2.2 and table 2.3 shows performance specification of D/A conversion module.

Items	Specifications			
	G4F-DA3I	G4F-DA2I	G4F-DA3V	G4F-DA2V
I/O points	16 points			
Digital input	16bit(data part :12bits)signed binary			
Analog output	DC 4 ~ 20mA (External load resistance less than 510 Ω)		-10 ~ 10 VDC (External load resistance :2K ~ 1M Ω)	
Max. resolution	4 μA(1/4000)		5 mV(1/4000)	
Accuracy	± 0.5% [Full Scale]			
Max. conversion speed (ms/channel)	15ms/ 8 channels	10ms/ 4 channels	15ms/ 8 channels	10ms/ 4 channels
Max. absolute input	DC 24mA		15 VDC	
Analog output points	8 channels/1module	4 channels/1module	8 channels/1module	4 channels/1module
Isolation	Between input terminals and the PLC: Photo-coupler isolation			
Terminals connected consumption	20-point terminal block			
Internal Current Consumption	70mA	680mA	700mA	400mA
External Power Supply	Voltage	DC21.6~26.4V		
	Current	220mA		
Weight	280 g	260 g	280 g	260 g

[Table 2.2] Performance Specifications

REMARK

- 1) GM4-PA1A and GM4-PA2A - DC5V:4A, DC24V:0.7A
- 2) GM4-PA1B and GM4-PA2B - DC5V:3A, DC24V:0.5A

Items	Specifications				
	G3F-DA3I	G6F-DA2I	G3F-DA3V	G6F-DA2V	
I/O points	16 points				
Digital input	16bit(data part :12bits)signed binary				
Analog output	DC 4 ~ 20mA (External load resistance less than 510 Ω)		0 ~ 10 VDC (External load resistance : 2K ~ 1M Ω)	-10 ~ 10 VDC (External load resistance : 2K ~ 1M Ω)	
Max. resolution	4 μA(1/4000)		2.5 mV(1/4000)	5 mV(1/4000)	
Accuracy	± 0.5% [Full Scale]				
Max. conversion speed (ms/channel)	15ms/ 8 channels	10ms/ 4 channels	15ms/ 8 channels	10ms/ 4 channels	
Max. absolute input	DC 24mA		15 VDC		
Analog output points	8 channels/1module	4 channels/1module	8 channels/1module	4 channels/1module	
Isolation	Between input terminals and the PLC: Photo-coupler isolation				
Terminals connected consumption	20-point terminal block	18-point terminal block	20-point terminal block	18-point terminal block	
Internal Current Consumption *1	+5VDC	70 mA	40 mA	600 mA	40 mA
	+15VDC	-	120 mA	-	80 mA
	-15VDC	-	25 mA	-	60 mA
External Power Supply	Voltage	DC21.6~26.4V			
	Current	220 mA			
Weight	410 g	200 g	390 g	200 g	

[Table 2.3] Performance Specifications

REMARK

*1 The capacity of the GM6-PAFB is +15VDC : 0.5A, -15VDC : 0.2A and when it is used to several D/A converter module simultaneously, please consider each D/A converter module to satisfy current consumption of it.
If it is used in the GM6 series or K200S series, please make sure to the GM6-PAFB of power supply Module.

2.3 Names of Parts and Functions

Names of parts and functions are shown as below.

1) G4F-DA3V/G4F-DA2V/G4F-DA3I/G4F-DA2I

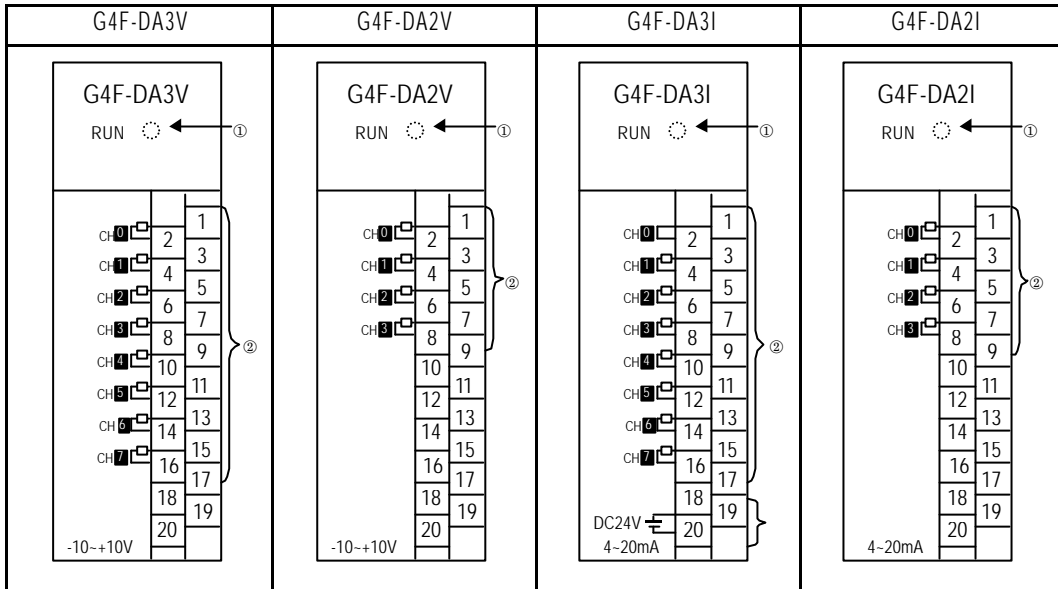

No.	Descriptions
	<p>RUN LED</p> <p>Indicates the operating condition of the D/A conversion module</p> <ul style="list-style-type: none"> * On: Normal operation * Off : 5 VDC power off or D/A conversion module fault
	<p>Analog output terminal block</p> <p>Terminal block which is output D/A conversion value of each channel to external.</p> <p>(G4F-DA3V/G4F-DA3I : 8 channels G4F-DA2V/G4F-DA2I : 4 channels)</p>
	<p>External input terminal block</p> <p>External voltage input terminal (No.19 ~ 20)</p>

2) G3F-DA3V/G3F-DA3I

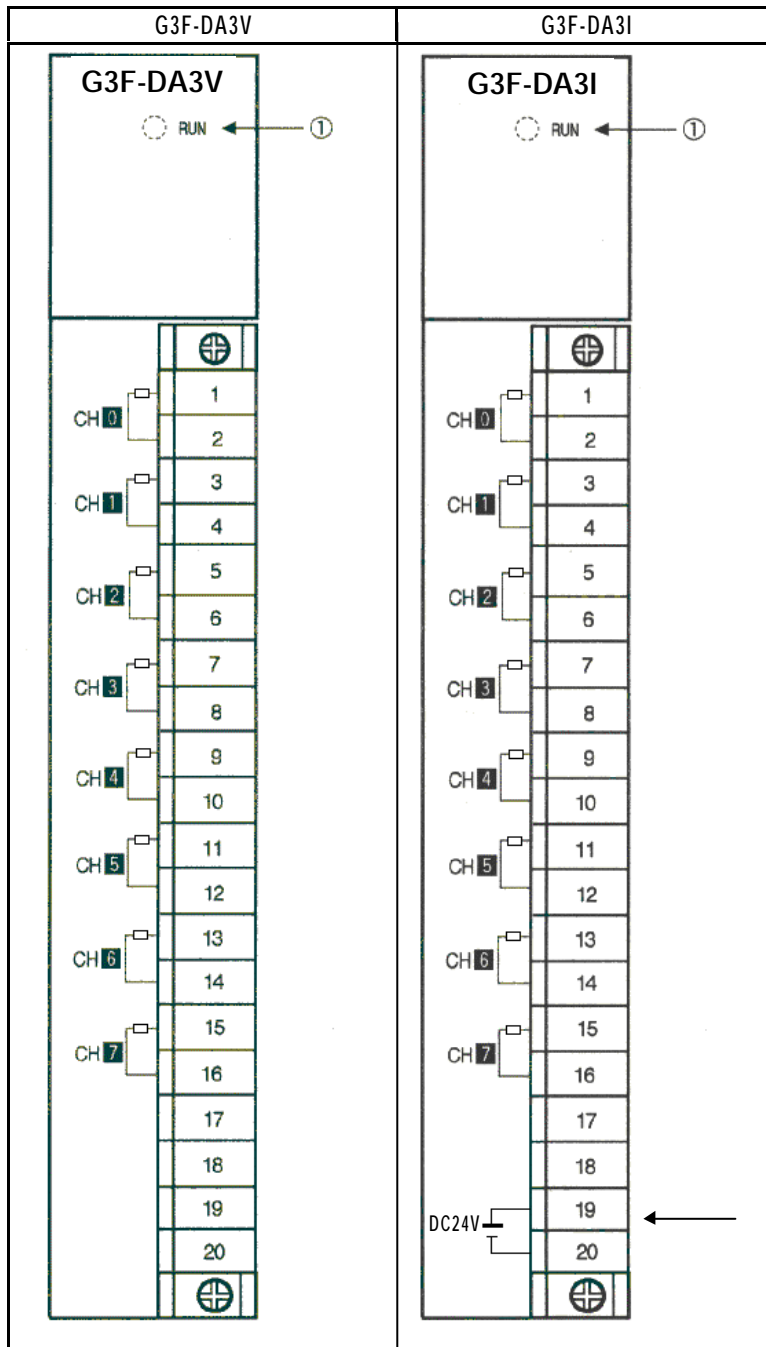

No	Descriptions	
	<table border="1"> <tr> <td>RUN LED</td> </tr> </table> <p>Indicates the operating condition of the D/A conversion module * On: Normal operation * Off : 5 VDC power off or D/A conversion module fault</p>	RUN LED
RUN LED		
	<table border="1"> <tr> <td>External input terminal block</td> </tr> </table> <p>External voltage 24VDC input terminal (No.19 ~ 20) : only G3F-DA3I</p>	External input terminal block
External input terminal block		

3) G6F-DA2V/G6F-DA2I

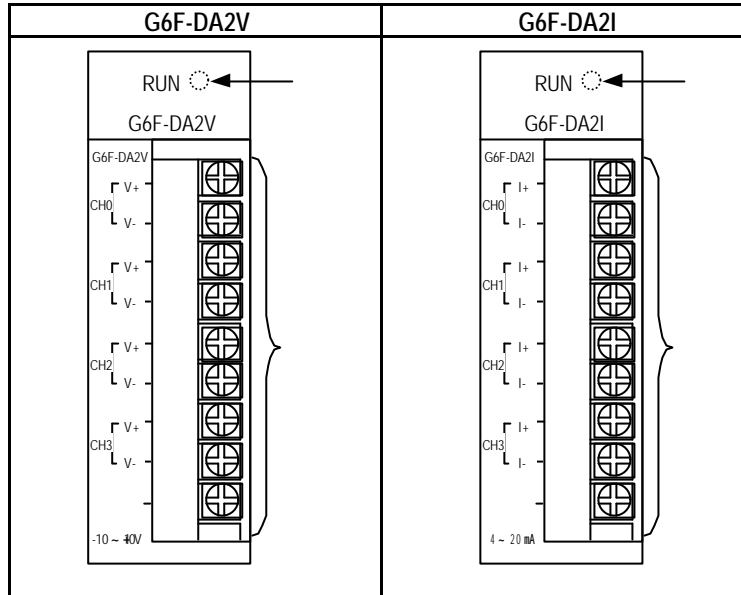

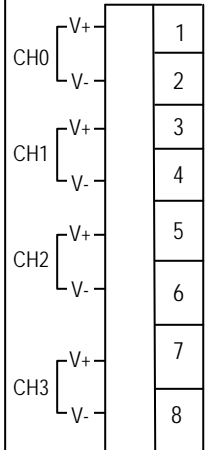
No	Descriptions
	<p>RUN LED</p> <p>Indicates the operating condition of the D/A conversion module</p> <ul style="list-style-type: none"> * On: Normal operation * Off : 5 VDC power off or D/A conversion module fault
	<p>External input terminal block</p>  <p>Terminal block which is output D/A conversion value of each channel to external.</p>

2.4 Input/Output Conversion Characteristics

I/O characteristics are displayed as a slant of the line connecting offset value and gain value in converting an digital signal from the external PLC into an analog signal(voltage or current).

Offset value and Gain value of D/A converter are fixed and should not be modified.

Input/ output conversion characteristic example is shown on Fig 2.1

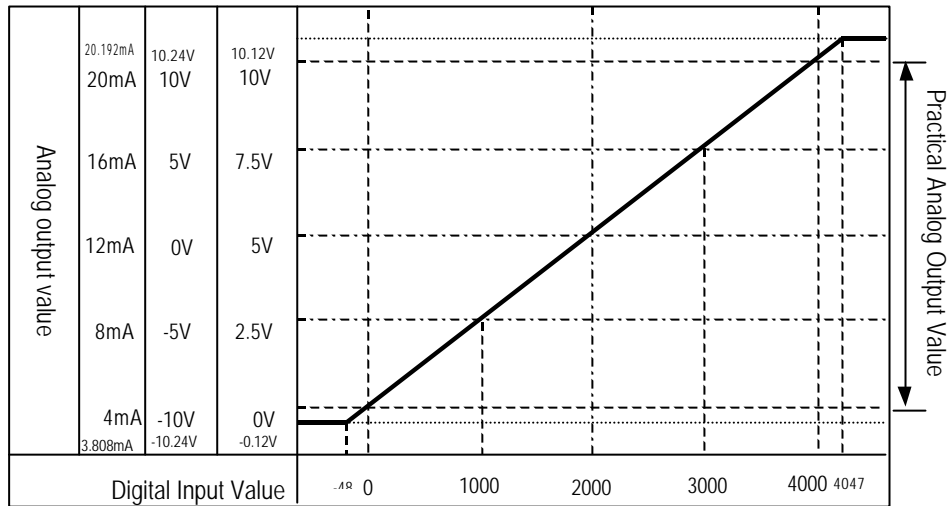

[Fig 2.1] Input/ output conversion characteristic example

G3F-DA3V : Digital input value of 1 is equal to 2.5mV.

G4F-DA3V/G4F-DA2V/G6F-DA2V : Digital input value of 1 is equal to 5mV.

G3F-DA3I/G4F-DA3I/G4F-DA2I/G6F-DA2I : Digital Input value of 1 is equal to 4 μ A.

CHAPTER 3. INSTALLATION AND WIRING

3.1 Installation

3.1.1 Installation Environment

This module has high reliability regardless of its installation ambience. But check the following for system in higher reliability and stability.

1) Ambience requirements

Avoid installing this unit in locations which are subjected or exposed to :

- Water leakage and a large amount of dust, power and other conductive powder, oil mist, salt of organic solvent
- Mechanical vibrations of impacts transmitted directly to the module body
- Direct sunlight.
- Dew condensation due to sudden temperature change.
- High or low temperatures (outside the range of 0-55°C)

2) Installation and wiring

- During wiring or other work, do not allow any wire scraps to enter into the PLC.
- Install it on locations that are convenient for operation.
- Make sure that it is not located near high voltage equipment on the same panel.
- Make sure that the distance from the walls of duct and external equipment be 50 mm or more.
- Be sure to be grounded to locations that have good noise immunity.

3.1.2 Installation Precautions

From unpacking to installation of the D/A conversion module, be sure to check the following:

- 1) Do not drop it off, and make sure that strong impacts should not be applied.
- 2) Do not dismount printed circuit board(PCB) from the case. It can cause malfunctions.
- 3) During wiring, be sure to check any foreign matter like wire scraps should not enter into the upper side of the PLC, and in the event that foreign matter entered into it, always eliminate it.
- 4) Be sure to disconnect electrical power before mounting or dismounting the module.

3.2 Wiring

3.2.1 Wiring Precautions

- 1) Separate AC and external input signal of D/A conversion module wiring not to be affected by surge or induced noise in the AC.
- 2) External wiring has to be at least AWG22(0.3mm²) and be selected in consideration of operating ambience and/or allowable current.
- 3) Separate wiring from devices and/or substances generating intense heat, and oil not to make short-circuit which leads to damage and/or mis-operation.
- 4) Identify the polarity of terminal block before external power supply is made connected.
- 5) Separate external wiring sufficiently from high voltage and power supply cable not to cause induced failure and/or malfunction.
- 6) Don't put the power cable in front of the LED display (To read the digital value on the LED correctly)

3.2.2 Wiring Examples

- 1) G3F-DA3V/G4F-DA3V/G4F-DA2V/G6F-DA2V

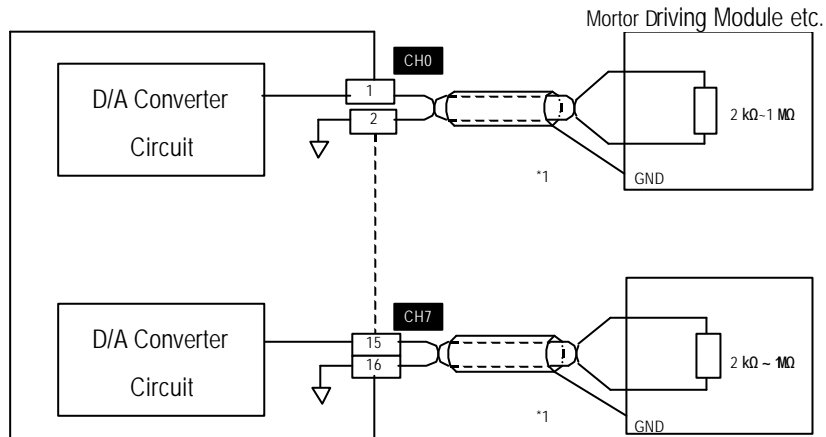

*1 For the cable, use a two-core twisted shielded wire.

2) G3F-DA3I/G4F-DA3I/G4F-DA2I/G6F-DA2I

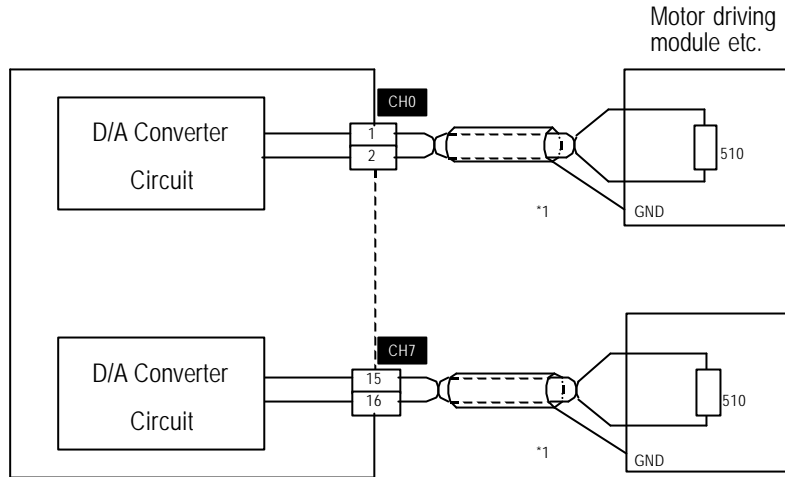

*1 For the cable, use a two-core twisted shielded wire.

Remark

Current output module(G3F-DA3I, G4F-DA3I, G4F-DA2I, G6F-DA2I) cannot be connected with device which is grounded with common line. Because it is not normal current output.

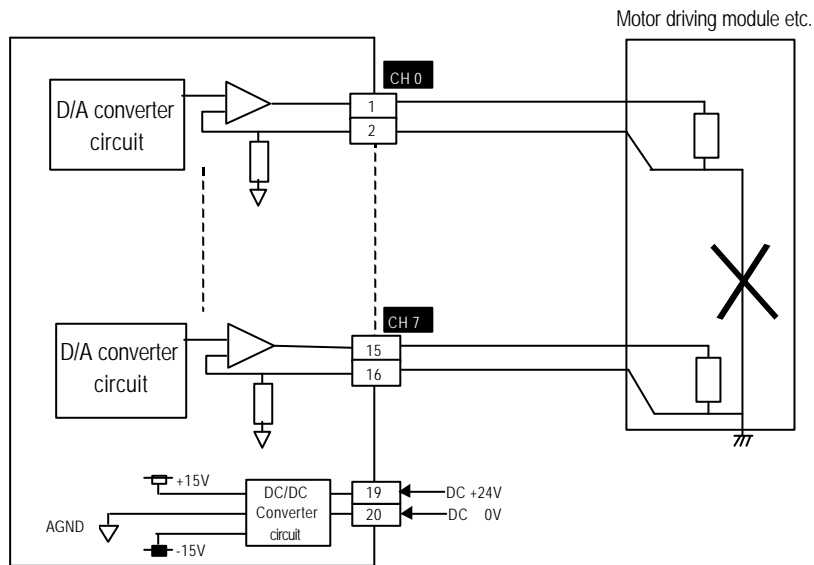

Chapter 4. FUNCTION BLOCK

This chapter shows function block for the D/A conversion module on the GMWIN.

A kind of function block is as follows

No.	G3F-DA3V,G3F-DA3I		G4F-DA3V,G4F-DA3I		G4F-DA2V,G4F-DA2I		G6F-DA2V,G6F-DA2I		Function
	Local	Remote	Local	Remote	Local	Remote	Local	Remote	
1	DA3AWR	DAR33WR	DA3AWR	DAR3WR	DA2AWR	DAR2WR	DA2AWR	DAR62WR	Writing D/A conversion (Array type)
2	DA3WR	-	DA3WR	-	DA2WR	-	DA2WR	-	Writing D/A conversion (Single type)

REMARK

1. Function block of the G3F-DA3V, G3F-DA3I, G4F-DA3V and G4F-DA3I are same
2. Function block of the G4F-DA2V, G4F-DA2I, G6F-DA2V and G6F-DA2I are same

4.1 Insertion of the Function Block for D/A Conversion Module on the GMWIN

A function block can be inserted during the execution of the GMWIN according to the following procedure.

A function block can be inserted only when a project opens.

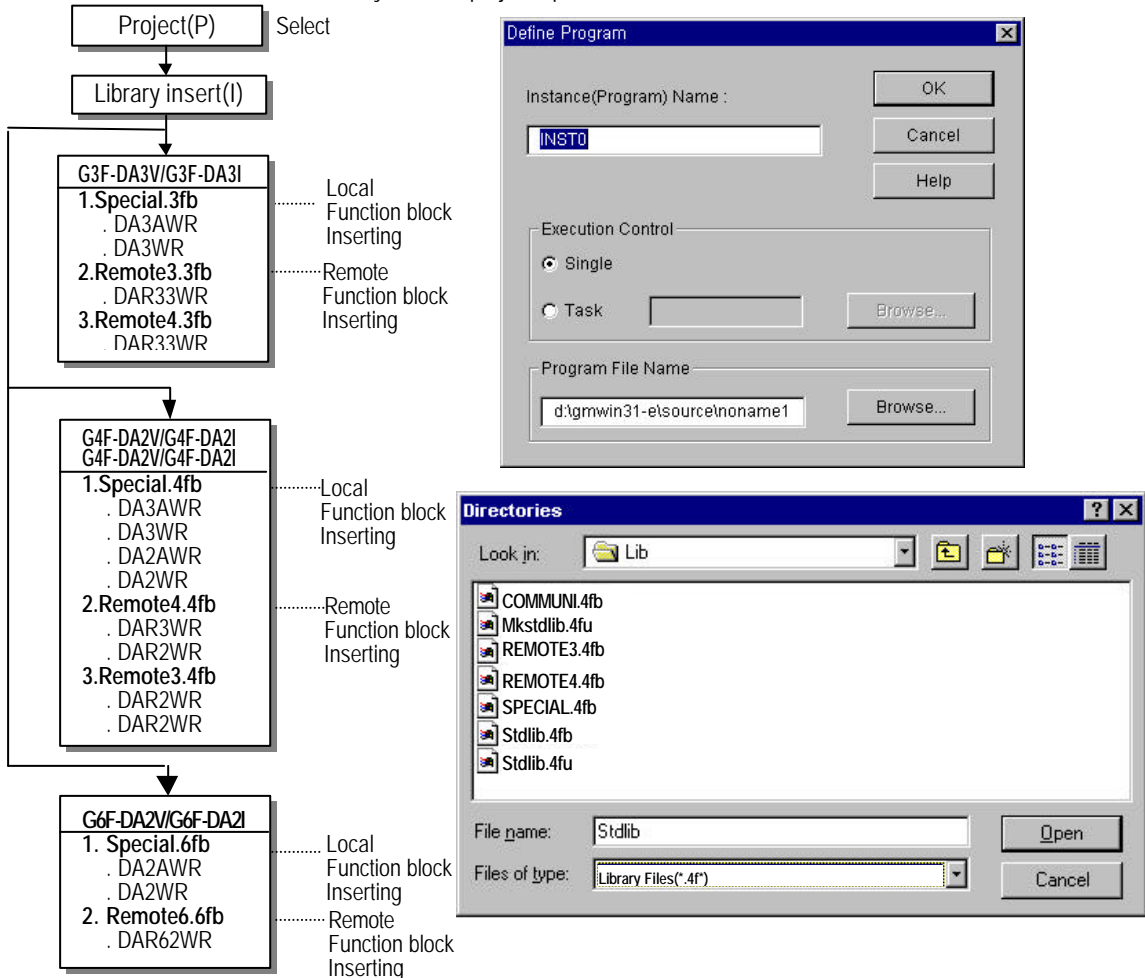

4.2 Function Blocks for Local

4.2.1 Module Write_ Array Type (G3F-DA3V,G3F-DA3I,G4F-DA3V,G4F-DA3I : DA3AWR, G4F-DA2V,G4F-DA2I,G6F-DA2V,G6F-DA2I : DA2AWR)

Module write function block of the Array type is a program for the use in performing for every channel in block and setting a digital value to be converted into a D/A conversion.

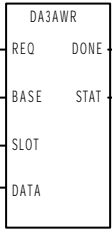
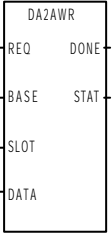
Function Block	I/O	Variable	Data Type	Descriptions
G3F-DA3V/DA3I G4F-DA3V/DA3I 	Input	REQ	BOOL	Function Block Execution Request Area -The execution of function block initialization is requested in this area. -If the status connected with this area is satisfied on the program execution and 0 is changed to 1, function block for the module is executed.
		BASE	USINT	Base Location Number Area -The base No. on which D/A conversion module is mounted is written on this area. -Setting range : G3F-DA3V,G3F-DA3I,G4F-DA3V,G4F-DA3I,G4F-DA2V,G4F-DA2I : 0 to 3 G6F-DA2V, G6F-DA2I : 0
		SLOT	USINT	Slot Location Number Area -The slot No. on which D/A conversion module is mounted is written on this area. -Setting range: 0 to 7
		DATA	INT [Array] *Note1	Input Data Type Specification Area -Input digital data type for each channel is specified in this area. -Setting range: 0 ~ 4000
G4F-DA2V/DA2I G6F-DA2V/DA2I 	Output	DONE	BOOL	Function Block Execution Complete Area - When function block has been completed with no error, 1 is written and until next execution, 1 is continuing. When error occurs, 0 is written and operation come to stop.
		STAT	USINT	Error Code Display Area - When error occurs during function block processing, the error code number is written. - For error code, refer to section 4.4.

Remark

Note 1: Array number of data type means the whole number of channels and channel number.
 Array number of G3F-DA3V/G3F-DA3I/G4F-DA3V/G4F-DA3I is 8 and array number of G4F-DA2V/G4F-DA2I /G6F-DA2V/G6F-DA2I is 4.

4.2.2 Module Write_Single Type(G3F-DA3V,G3F-DA3I,G4F-DA3V,G4F-DA3I : DA3WR, G4F-DA2V,G4F-DA2I,G6F-DA2V,G6F-DA2I : DA2WR)

Module write function block of the Single type is a program for the use in performing for a channel of D/A conversion module and setting a digital value to be converted into a D/A conversion.

Function block	I/O	Variable	Data type	Descriptions
G3F-DA3V/DA3I G4F-DA3V/DA3I <div style="border: 1px solid black; padding: 5px; width: fit-content;"> DA3WR REQ DONE BASE STAT SLOT CH DATA </div>	Input	REQ	BOOL	Function Block Execution Request Area -The execution of function block is requested in this area. - If the status connected with this area is satisfied on the program execution and 0 is changed to 1, function block for the module is executed.
		BASE	USINT	Base Location Number Area - The base No. on which D/A conversion module is mounted is written on this area. - Setting range : G3F-DA3V,G3F-DA3I,G4F-DA3V,G4F-DA3I,G4F-DA2V,G4F-DA2I : 0 to 3 G6F-DA2V, G6F-DA2I : 0
		SLOT	USINT	Slot Location Number Area - The slot No. on which D/A conversion module is mounted is written on this area. - Setting range: 0 to 7
		CH	USINT	Available Channel Specification Area - Available channels are specified in this area. - Range : G3F-DA3V,G3F-DA3I,G4F-DA3V,G4F-DA3I : 0 to 3 G4F-DA2V,G4F-DA2I,G6F-DA2V, G6F-DA2I : 0
		DATA	INT	Input Data Type Specification Area -Input digital data type for each channel is specified in this area. -Setting range: 0 ~ 4000
	G4F-DA2V/DA2I G6F-DA2V/DA2I <div style="border: 1px solid black; padding: 5px; width: fit-content;"> DA2WR REQ DONE BASE STAT SLOT CH DATA </div>	output	DONE	BOOL
STAT		USINT	Error Code Display Area - When error occurs during function block processing, the error code number is written. - For error code, refer to section 4.4.	

4.3 Remote Function Block

4.3.1 Module write : (G3F-DA3V/G3F-DA3I : DAR33WR, G4F-DA3V/G4F-DA3I : DAR3WR, G4F-DA2V/G4F-DA2I : DAR2WR, G6F-DA2V/G6F-DA2I : DAR62WR)

Module write function block of the Single type is a program for the use in performing for a channel of D/A conversion module and setting a digital value to be converted into a D/A conversion.

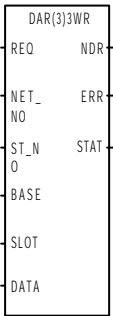
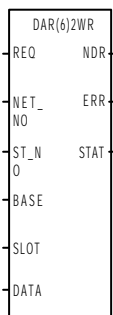
Function block	I/O	Variable	Data type	Descriptions
G3F-DA3V/DA3I G4F-DA3V/DA3I 	Input	REQ	BOOL	Function Block Execution Request Area on Rising Edge. - The execution of write function block is requested in this area. - If the status to be connected with this area is satisfied on the program operation and input condition changes from low(0) to high(1), function block initialization for the module is executed.
		NET_NO	USINT	The location number of the slot on which the transmission module of the master station is mounted. -Setting range: 0 to 7
		ST_NO	USINT	Station number of the communication module which a remote I/O station has. - Setting range : 0 to 63
		BASE	USINT	Base Location Number Area - The base No. on which A/D conversion module is mounted is written on this area. - Setting range : G3F-DA3V,G3F-DA3I,G4F-DA3V,G4F-DA3I,G4F-DA2V,G4F-DA2I : 0 to 3 G6F-DA2V,G6F-DA2I : 0
		SLOT	USINT	Slot Location Number Area - The slot No. on which A/D conversion module is mounted is written on this area. - Setting range: 0 to 7
		DATA	INT [Array] *Note1	Input Data Type Specification Area -Input digital data type for each channel is specified in this area. -Setting range : 0 ~ 4000
		G4F-DA2V/DA2I G6F-DA2V/DA2I 	Output	NDR
ERR	BOOL			Error Data Display Area - When error occurs during function block initialization, 1 is written and the operation comes to stop. During the scan which the execution condition has been made, 1 is continuing and at the next scan, 0 is written.
STAT	USINT			Error Code Display Area - When error occurs during function block initialization, the error code number is written.

REMARK
 Note 1: Array number of data type means the whole number of channels and channel number.
 Array number of G3F-DA3V/G3F-DA3I/G4F-DA3V/G4F-DA3I is 8 and array number of G4F-DA2V/G4F-DA2I/G6F-DA2V/G6F-DA2I is 4.

4.4 Errors on Function Block

This shows the errors on the output variable "STAT" of variables and the resolutions in accordance with them.

STAT No.	Local/Remote	Descriptions	Function Block		Resolutions
			Array type	Single type	
0	Local	Operating with no fault	0	0	-
1		The base location number is exceeding the proper setting range	0	0	Correct the number in accordance with the proper range (See Manual 4.2)
2		H/W error of the base	0	0	Contact the service station.
3		The slot location number is exceeding the proper setting range	0	0	Set the right number to the slot mounting the D/A conversion module
4		The D/A conversion module on the slot is empty	0	0	Mount the D/A conversion module to the specified slot
5		The module loaded isn't the D/A module	0	0	Mount the D/A conversion module to the specified slot
6		The channel number is exceeding the proper range	-	0	Specify the available channel correctly
7		H/W error of the D/A conversion module	0	0	Contact the service station.
8		The D/A conversion module's shared memory error	0	0	Contact the service station.
128	Remote	H/W error of the communication module for remote	0	-	See the manual for the remote communication module
129		The base location number is exceeding the proper setting range	0		Correct the number in accordance with the proper range (See Section 4.2)
131		The slot location number is exceeding the proper setting range	0		Set the right number to the slot mounting the D/A conversion module
133		The module loaded isn't the D/A module	0		Mount the D/A conversion module to the specified slot
135		H/W error of the D/A conversion module	0		Contact the service station
136		The D/A conversion module's shared memory error	0		Contact the service station

Chapter 5. GM PROGRAMMING

5.1 Programming for Controlling Inverter Speed with 5 Step Analog Output Voltage

1) System Configuration

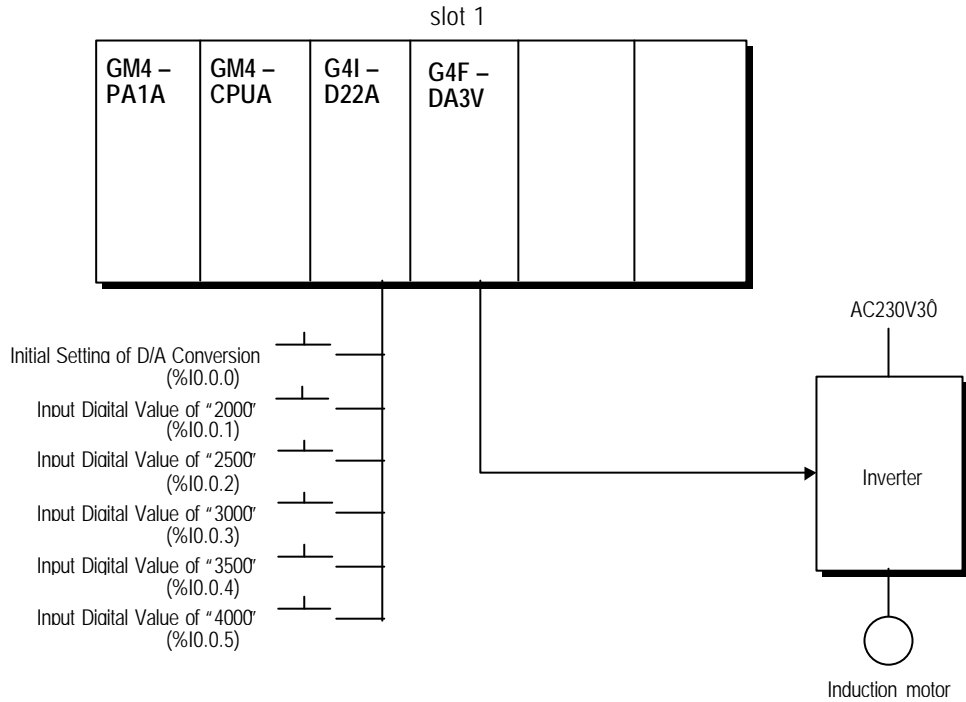

2) Initial Settings

- (1) Enabled channel : channel 0

3) Descriptions of the Program

- (1) %I0.0.0 turning On leads to write digital value to D/A conversion module.
- (2) %I0.0.1 turning On leads to output of "2000"(0 V) on channel 0.
- (3) %I0.0.2 turning On leads to output of "2500"(2.5 V) on channel 0
- (4) %I0.0.3 turning On leads to output of "3000"(5 V) on channel 0.
- (5) %I0.0.4 turning On leads to output of "3500"(7.5 V) on channel 0.
- (6) %I0.0.5 turning On leads to output of "4000"(10 V) on channel 0.

4) Program

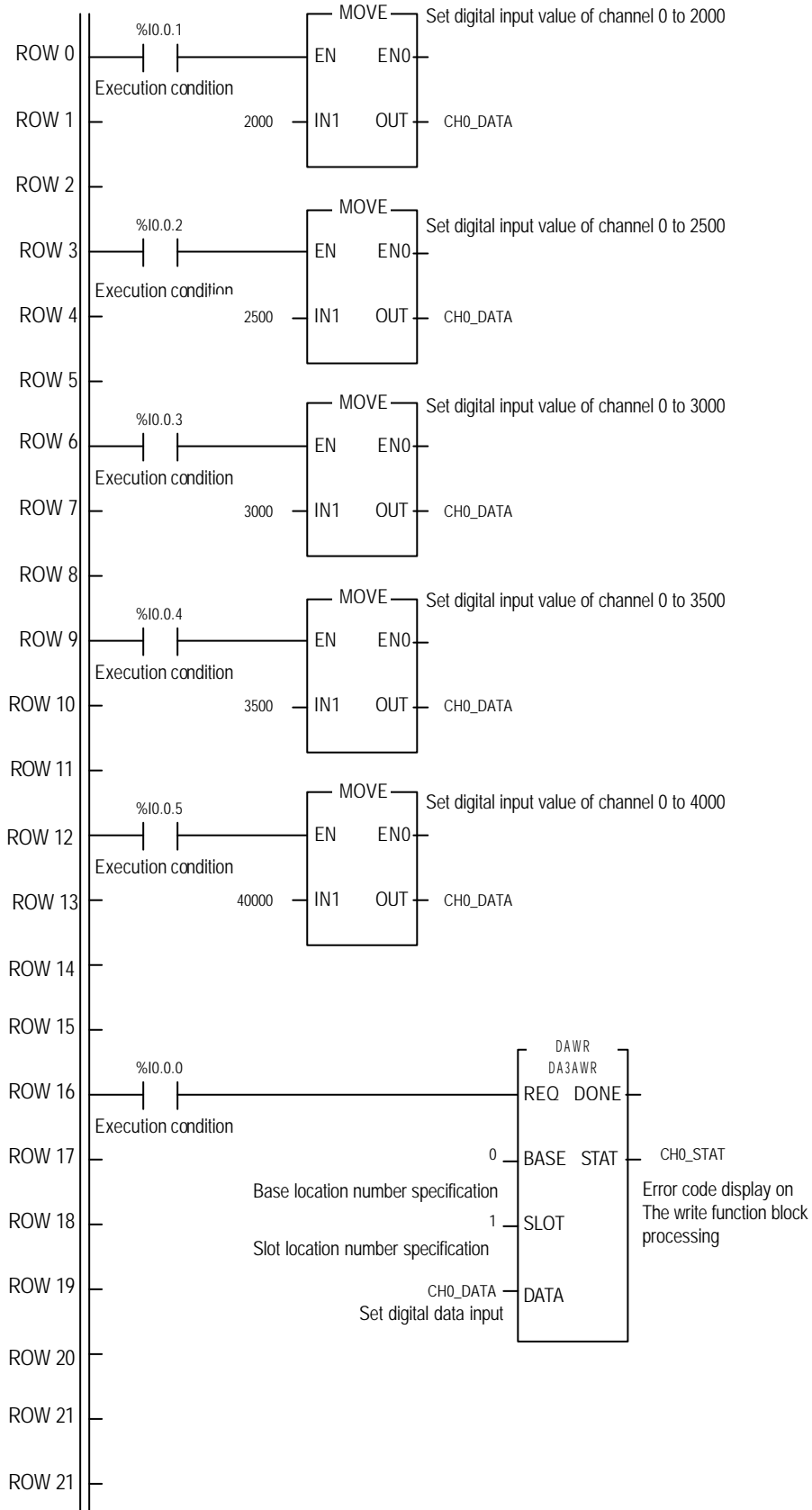

5) Digital value setting of I/O Variables

This denotes 8 channels

Select this and this screen appears

Select this and this screen appears

To Select previous Ch.

To Select next Ch.

Channel No.

Digital Value

Set digital data input

5.2 Programming for Displaying D/A Conversions which is Set by Digital Switch

1) System Configuration

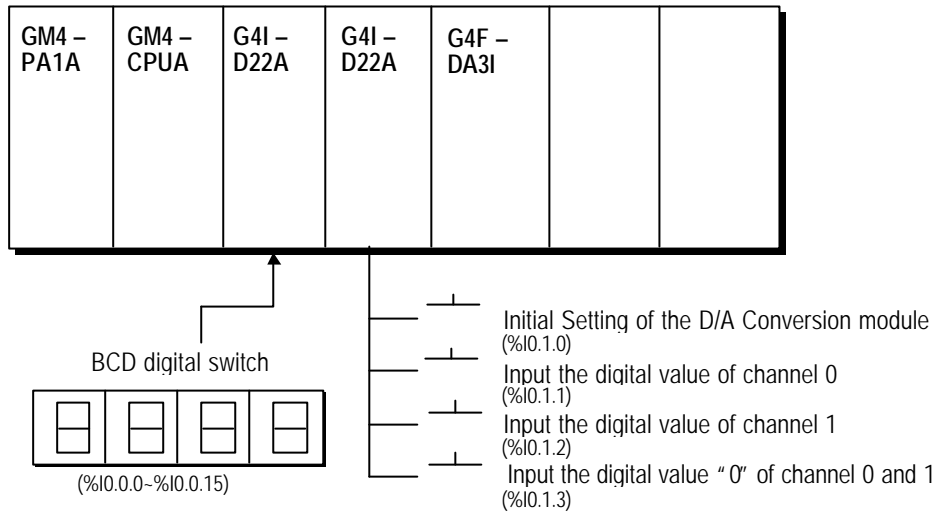

2) Initial Settings

(1) Enabled channel : channel 0, 1

3) Descriptions of the Program

- (1) %I0.1.0 turning On leads to write the digital value to D/A conversion module.
- (2) %I0.1.1 turning On leads to output of the values by digital switch on channel 0 of D/A module.
- (3) %I0.1.2 turning On leads to output on channel 1.
- (4) %I0.1.3 turning On leads to initialization of digital input value to "0" on channel 0 and channel 1.

4) Program

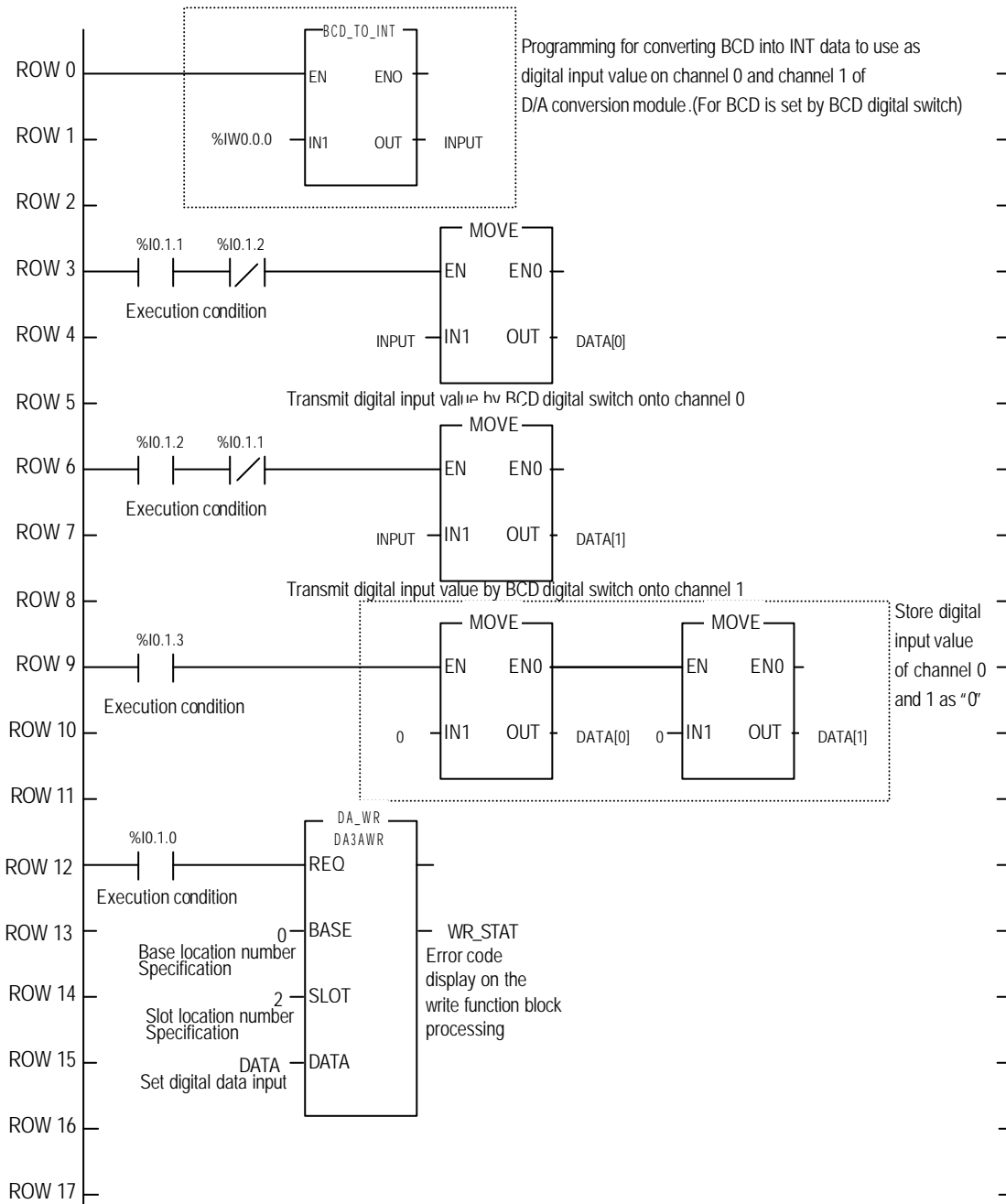

5) I/O Variables on Program

Variable name	Var_Kind	Data Type	(AT Address) (Initial Value)
INPUT	: VAR	: DINT	
OUTPUT	: VAR	: INT	
DA_WR	: VAR	: FB Instance	
WR_STAT	: VAR	: USINT	
DATA	: VAR	: ARRAY[0..7] OF INT	: = {0,0,0,0,0,0,0,0}

5.3 Programming for Mounting D/A Conversion Module on Remote I/O Station

This is programming for output D/A conversion value set by digital switch.

1) System Configuration

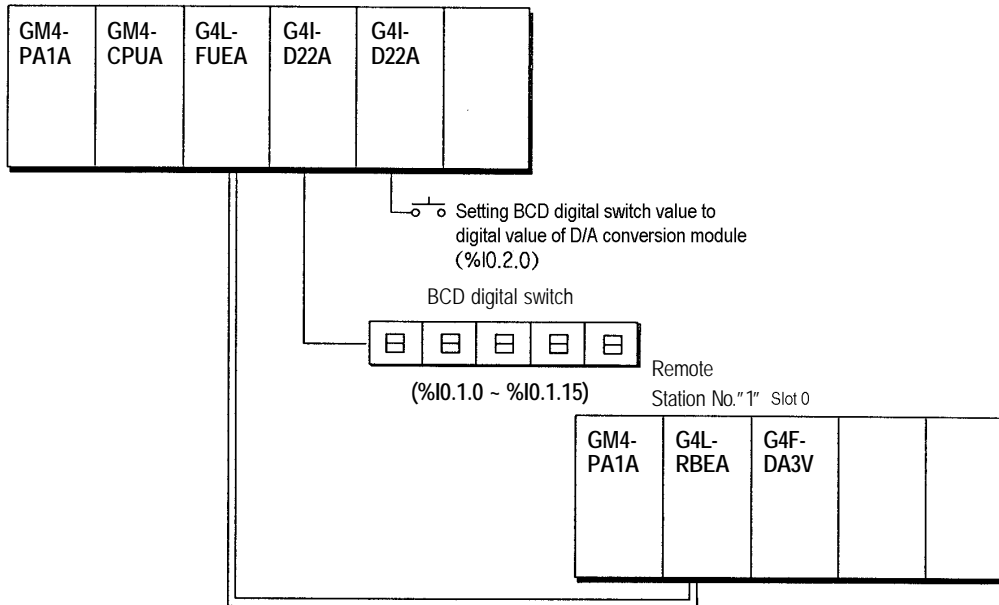

2) Descriptions of the Program

(1) %I0.2.0 turning On leads to displaying D/A conversion value set by digital switch on channel 0.

4) Program

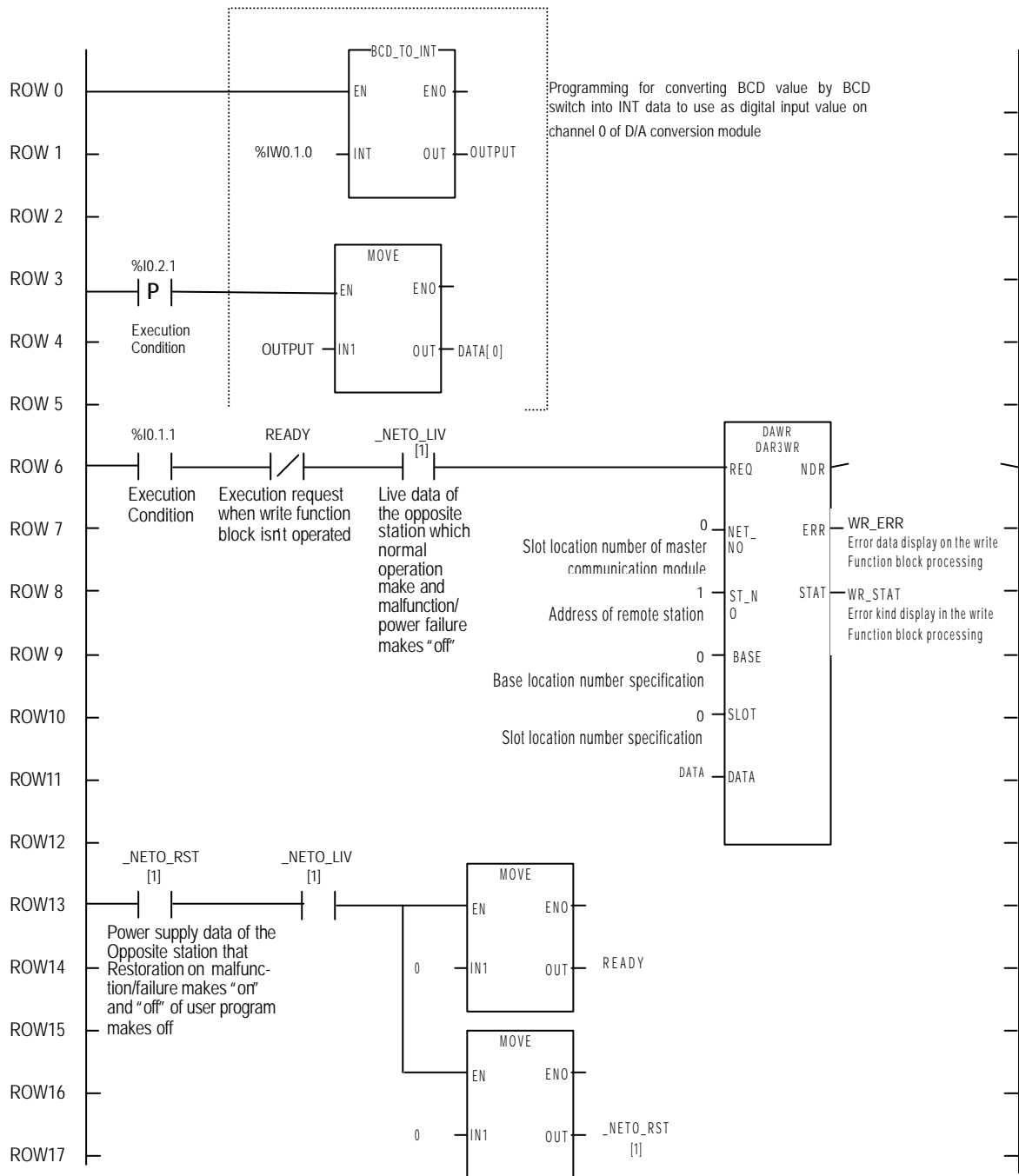

5) I/O Variables on Program

Variable name	Var_Kind	Data Type	(AT Address) (Initial Value)
DATA	: VAR	: ARRAY[0..7] OF INT	:= {0,0,0,0,0,0,0,0}
DAWR	: VAR	: FB Instance	
OUTPUT	: VAR	: INT	
READY	: VAR	: BOOL	
WR_ERR	: VAR	: BOOL	
WR_STAT	: VAR	: USINT	

Chapter 6. BUFFER MEMORY CONFIGURATION AND FUNCTIONS

The D/A conversion module has the buffer memory for communication of data with the PLC CPU.

6.1 Buffer Memory Configuration

This shows buffer memory configuration.

Address (decimal)	G3F-DA3V G4F-DA3V	G4F-DA2V G6F-DA2V	G3F-DA3I G4F-DA3I	G4F-DA2I G6F-DA2I	Descriptions	Detail Descriptions	Non-initialization	Remarks
0					Digital input value specification to channel 0	Specify digital data for D/A conversion to these areas. (-48~4047)	G4F-DA3V / G4F-DA2V / G6F-DA2V : Digital data is specified to "2000". G4F-DA3I / G4F-DA2I / G6F-DA2I / G3F-DA3I / G3F-DA3V: Digital data is specified to "0".	R/W
1					Digital input value specification to channel 1			"
2					Digital input value specification to channel 2			"
3					Digital input value specification to channel 3			"
4		-		-	Digital input value specification to channel 4			"
5		-		-	Digital input value specification to channel 5			"
6		-		-	Digital input value specification to channel 6			"
7		-		-	Digital input value specification to channel 7			"

The buffer memory of G3F-DA3V, G3F-DA3I, G4F-DA3V and G4F-DA3I are same. And the buffer memory of G4F-DA2V, G6F-DA2V, G4F-DA2I and G6F-DA2I are same.

6.2 Buffer Memory Function

Each address of buffer memory has been occupied by one word, and it is displayed as 16 Bit.

Each address is composed of 16 Bit, and each Bit can be executed by specifying Bit on to 1 or Bit off to 0.

- 1) Digital input value can be used within the range 0 to 4000.
- 2) When digital input value isn't set, digital input value has to be set as follows.

Voltage output(G4F-DA3V/G4F-DA2V/G6F-DA2V) : 2000

Current output(G3F-DA3I/G4F-DA3I/G4F-DA2I/G6F-DA2I) : 0

Voltage output(G3F-DA3V) : 0

Chapter 7. SPECIAL MODULE COMMAND(BUFFER MEMORY READ/WRITE)

7.1 LOCAL COMMAND

Buffer Memory Write - PUT, PUTP Command

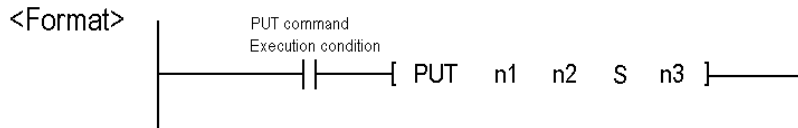

Symbol	Descriptions	Device used
n1	Slot number assigned to special module	Integer
n2	Head address of buffer memory of special module which stores data to write.	Integer
D	Head address of device which stores data to write.	M, P, K, L, T, C, D, #D
n3	Number of words of data to write	Integer

<Distinction of PUT and PUTP>

PUT: Continuously executes write while the write signal is on. 

PUTP: Execute write by switching on the write signal. 

ex1) D/A conversion module is mounted on the slot 6 of base, and data from the CPU module D2 and D3 is written to the buffer memory address 2, and 3.

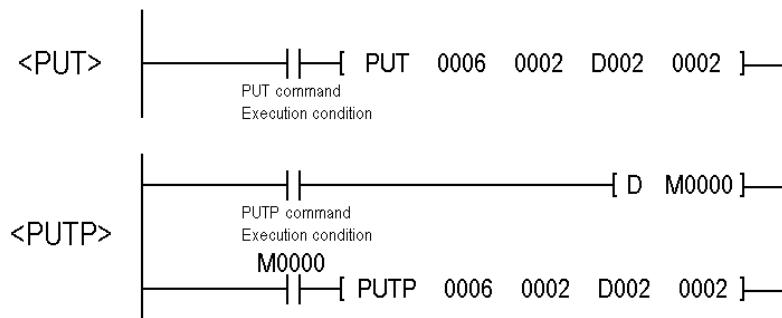
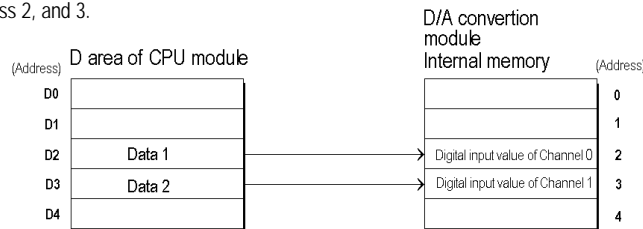

7.2 REMOTE COMMAND

Buffer Memory Write –RPUT

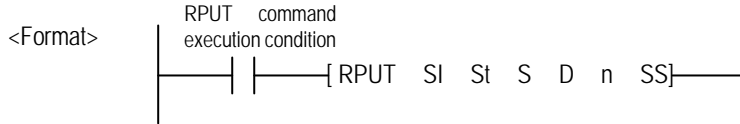

Symbol	Descriptions	Device used
SI	<div style="display: flex; justify-content: space-around; border: 1px solid black; padding: 2px;"> <div style="border: 1px solid black; padding: 2px;">A B</div> <div style="border: 1px solid black; padding: 2px;">C D</div> </div> <p>Upper (8bit) Lower (8bit)</p> <p>Upper(AB) : the code value of D/A conversion Module G3F-DA3V:h42, G4F-DA3V:hC4, G4F-DA2V:hC3, G6F-DA 2V:h0A, G3F-DA3l:h41, G4F-DA3l:hC2, G4F-DA2l:hC1, G6F-DA2l:h11 Lower(CD) : the slot number of communication module of the master station(FUEA). setting range: 0 to 7</p>	Integer
St	<div style="display: flex; justify-content: space-around; border: 1px solid black; padding: 2px;"> <div style="border: 1px solid black; padding: 2px;">E F</div> <div style="border: 1px solid black; padding: 2px;">G H</div> </div> <p>Upper (8bit) Lower (8bit)</p> <p>Upper(EF): Slot number of D/A conversion module of remote station. setting range: 0 to 31 Lower(GH):Address number of communication module of remote station(RBEA). setting range :0 to 63</p>	Integer
S	Head address of special module which stores data to write.	Integer
D	Head address of device which stores data to write.	M, P, K, L, T, C, D, #D
n	Number of words of data to write.	Integer, D
Ss	Condition data display space of link	M, P, K, L, T, C, D, #D

REMARK
To write on buffer memory data of D/A conversion module with RPUT command, configure the program so that execution condition of 0 will be changed into 1 on rising edge. Otherwise buffer memory data of D/A conversion module won't be updated

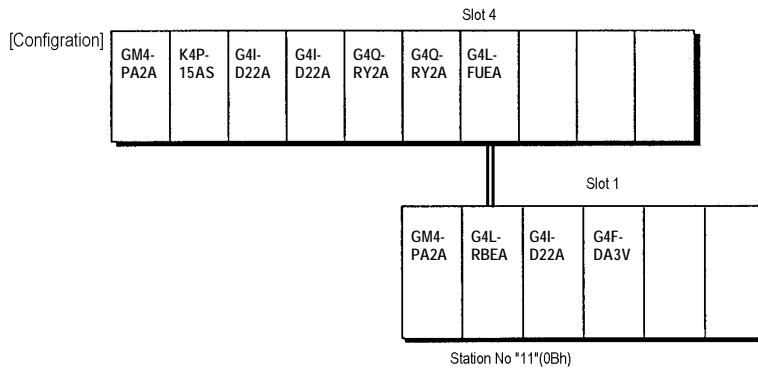

[Buffer memory write]

- 1) Write data on D100 to D107(8words) of the CPU module device
- 2) onto buffer memory address 0 to 7 of D/A conversion module
- 3) and store the data of communication to D0.

[Program]

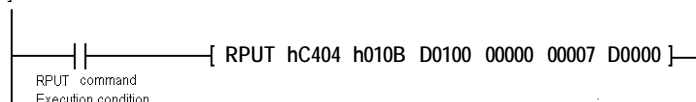

Chapter 8. MK PROGRAMMING

8.1 BASIC PROGRAMMING

- This shows the method of operation condition setting for internal memory on the D/A conversion module.
- The D/A conversion module is mounted on the slot 2.
- D/A conversion module occupies 16 I/O points.

8.1.1 G3F-DA3V / G3F-DA3I / G4F-DA3V / G4F-DA3I

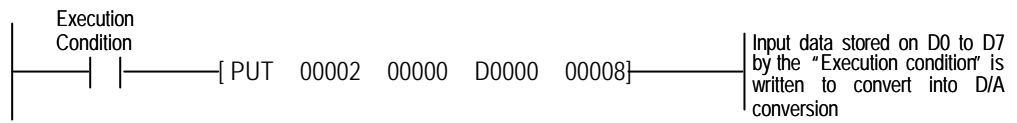

8.1.2 G4F-DA2V / G6F-DA2V / G4F-DA2I / G6F-DA2I

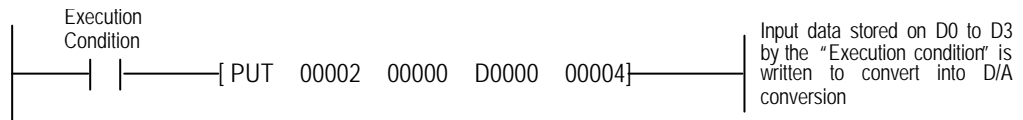

Remark

·With G3F-DA3V, G3F-DA3I, G4F-DA3V, G4F-DA3I, G4F-DA2V, G4F-DA2I, G6F-DA2V and G6F-DA2I users can not define set data.

8.2 Application Programming

8.2.1 Programming for Controlling Inverter Speed with 5-step Analog Output Voltage

1) System Configuration

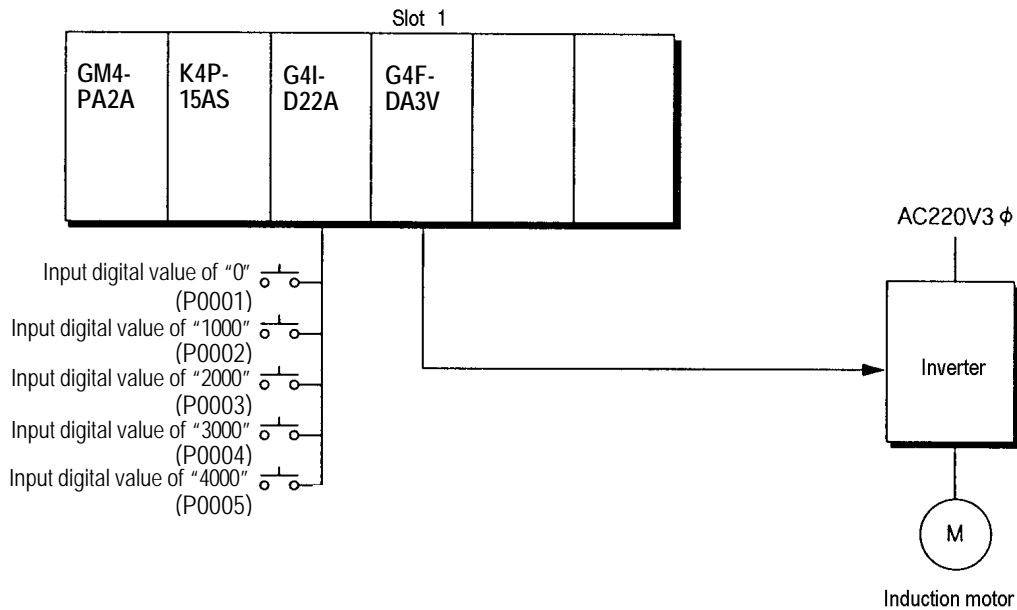

2) Initial Settings

- (1) Enabled channel : channel 0

3) Descriptions of the Program

- (1) P0001 turning On leads to output of "0"(-10 V) on channel 0.
- (2) P0002 turning On leads to output of "1000"(-5 V) on channel 0
- (3) P0003 turning On leads to output of "2000"(0 V) on channel 0.
- (4) P0004 turning On leads to output of "3000"(5 V) on channel 0.
- (5) P0005 turning On leads to output of "4000"(10 V) on channel 0.

4) Program

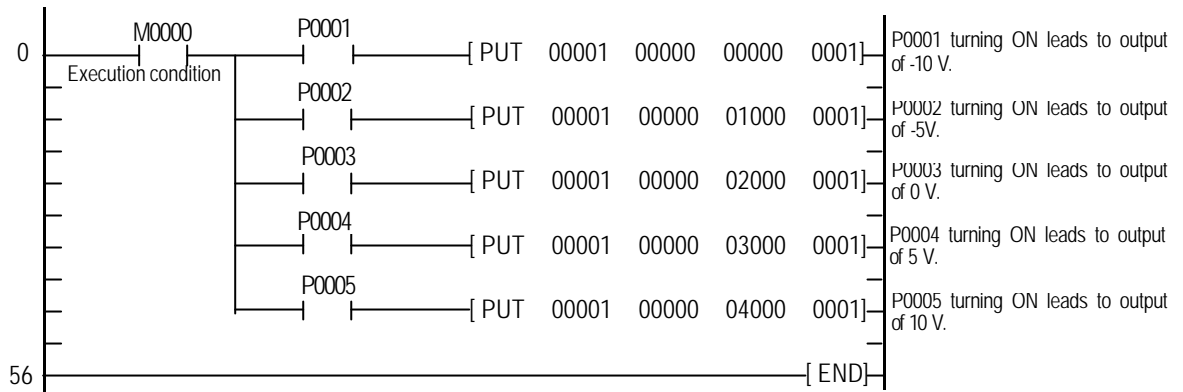

8.2.2 Programming for Displaying D/A Conversions which is Set by Digital Switch

1) System Configuration

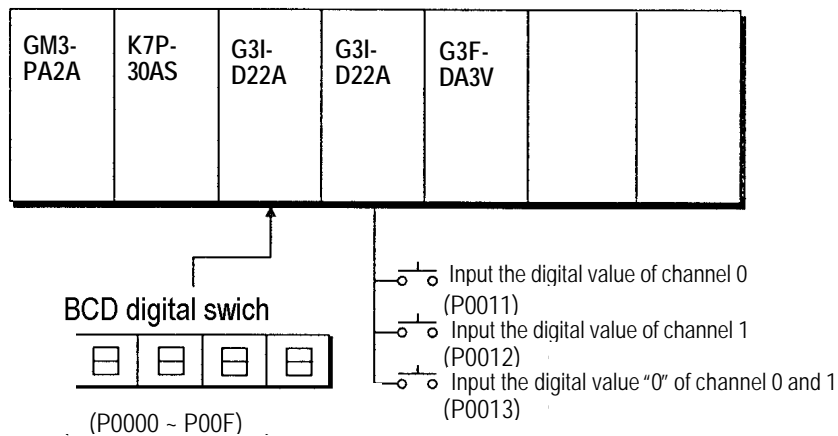

2) Initial Settings

- (1) Enabled channel : channel 0, 1

3) Descriptions of the Program

- (1) P0021 turning On leads to output of the values by digital switch on channel 0 of D/A module.
- (2) P0022 turning On leads to output on channel 1.
- (3) P0023 turning On leads to initialization of digital input value to "0" on channel 0 and channel 1.

4) Program

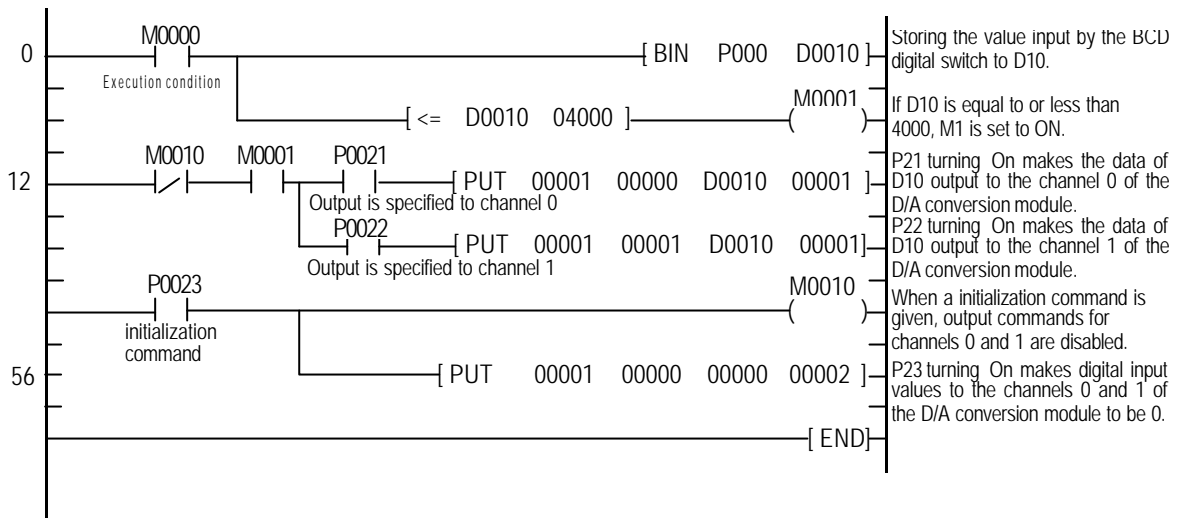

Chapter 9. DIMENSIONS

9.1 G3F-DA3V/G3F-DA3I

(Unit : mm)

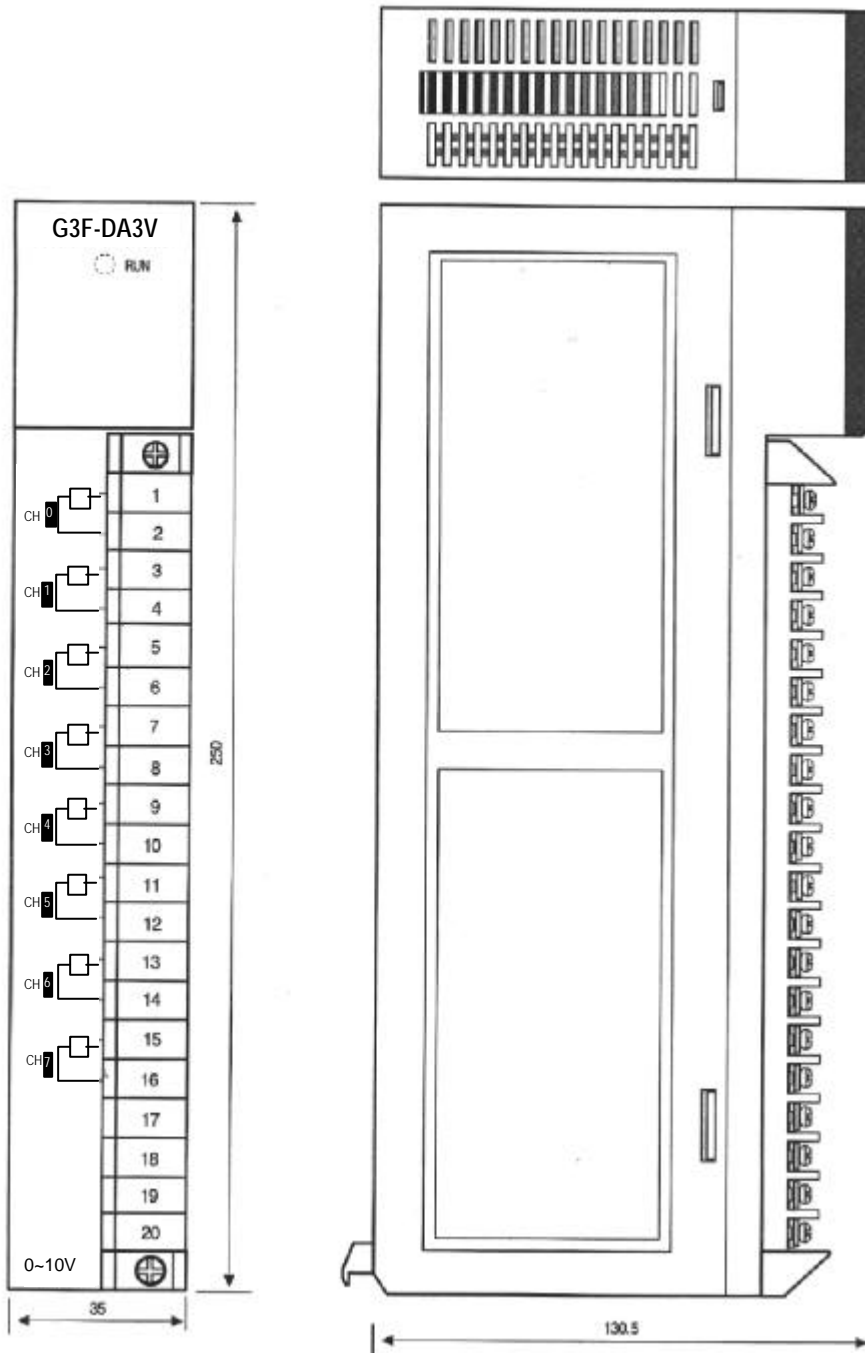

9.2 G4F-DA3V/G4F-DA3I/G4F-DA2V/G4F-DA2I

(Unit : mm)

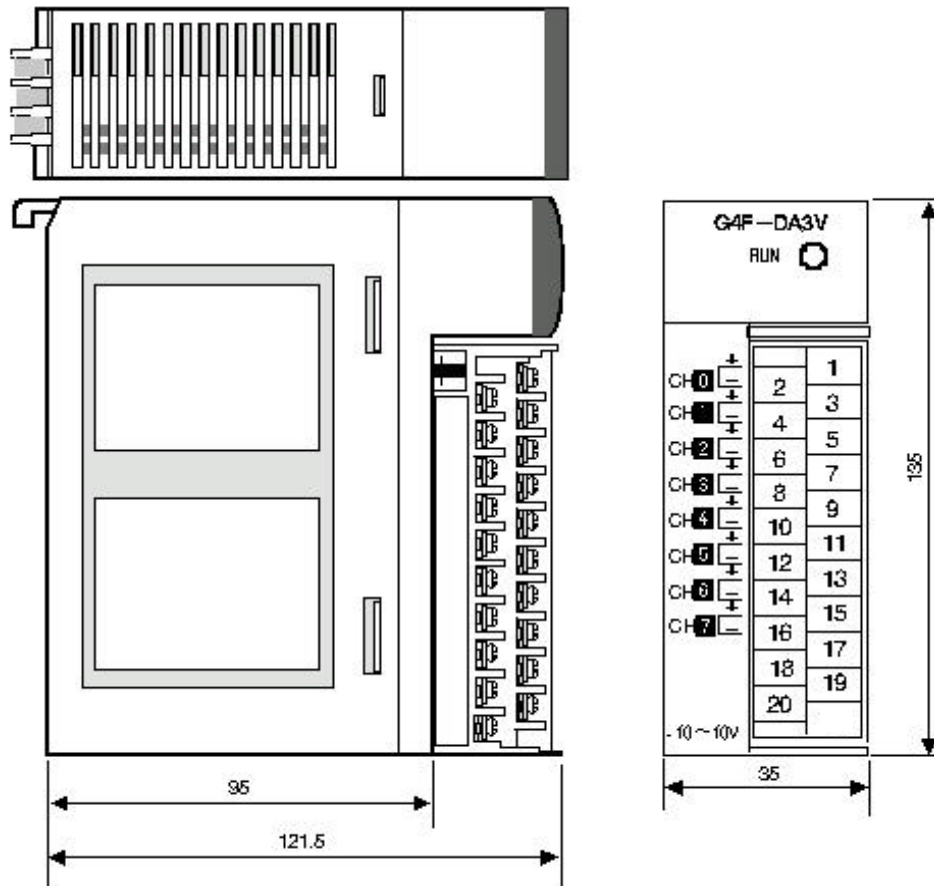

9.3 G6F-DA2V/G6F-DA2I

(Unit : mm)

